

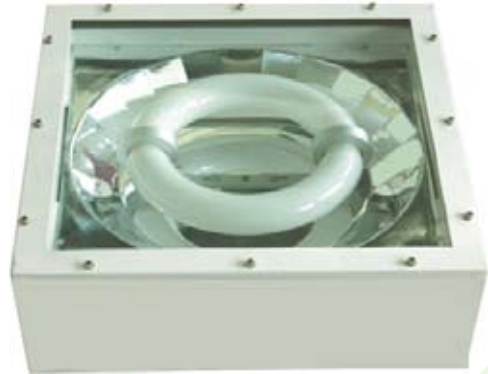

SPECIAL LIGHTING FIXTURE
GL-GSX01

Gas Station Fixture



Fixture sizes (Unit: mm)

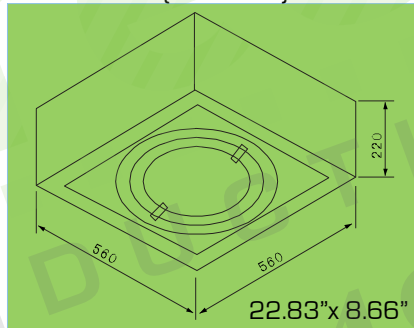

Features

- 1.Housing: Imported cold-rolled steel plate, static spraying surface
- 2.Reflector: High pure aluminum reflector, high light reflectivity, fade-proof in long term application.
- 3.Cover: Tempered glass lamp cover, stainless steel outer fixed parts.
- 4.Excellent dust and corrosion proof performance
- 5.Can match with our GL-Y80~200H lamp with its excellent Color Rendering Index and light efficiency, long life span, no flicker and energy saving, wide range of color temperature and soft light, stable light output.
- 6.IP Class: IP54
- 7.Application: petrol station, warehouse, toll gates, plant station, parking lots, etc

Distribution curve flux

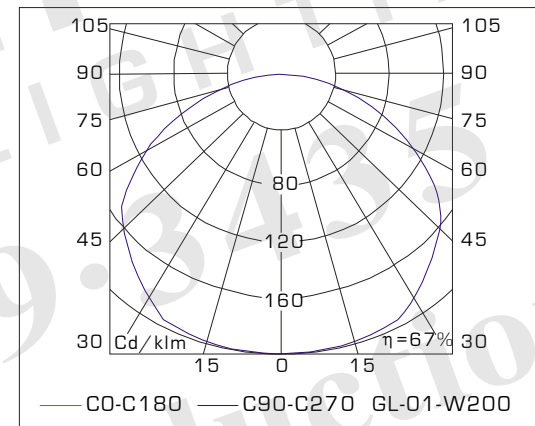

Specifications

Model	Lamp	Power (W)	Voltage (V)	Power factor (COS φ)	Environ Temp (°)	CCT (K)	Replace MH lamp
GL-MX01-W80	GL-Y80H850W/Z	80	120-277	≥ 0.96	-20~+40 □	5000K	150W
GL-MX01-W100	GL-Y100H850W/Z	100	120-277	≥ 0.96	-20~+40 □	5000K	150W
GL-MX01-W120	GL-Y120H850W/Z	120	120-277	≥ 0.96	-20~+40 □	5000K	175W
GL-MX01-W150	GL-Y150H850W/Z	150	120-277	≥ 0.96	-20~+40 □	5000K	250W
GL-MX01-W200	GL-Y200H850W/Z	200	120-277	≥ 0.96	-20~+40 □	5000K	400W

Note: The products with CCT 2700K~6500K and another input voltage are available.



Questions and Comments:
gregory@greenlightinduction.com
Office Number 949-429-3435